



BETTER WAY
LIGHTING

6 CHANNEL X 7 AMP ON BOARD DISPLAY

Product number: *BWL-6x7-OBD-16*



CE RoHS



The BWL-6x7-OBD-16 is a 4-channel DMX decoder designed to be robust and reliable on any film set. Using its high PWM output frequency of 5/10/20/30 KHz it avoids flicker. The frequency and integrated DMX addresses are set by using the buttons and display. Four output channels makes it compatible with our hybrid and RGB LED lighting solutions with up to 4 amps per channel. Two RJ45 jacks are built in for DMX input and output.

betterwaylighting.com • 778.772.3295

Copyright Better Way Lighting - All Rights Reserved 2018



6 CHANNEL X 7 AMP ON BOARD DISPLAY

Product number: BWL-6x7-OBD-16

Features

- Follows DMX 512 protocol.
- 8 bit /16 bit brightness control.
- Ideal control for RGB- BI LED tape.
- Direct manual control using the LCD screen and buttons.
- The 6 output terminals provide 6 independently controllable channels of constant-voltage PWM dimming, and the two positive power input terminals are also used as common anode power output terminals (shared positive).
- Converts standard DMX signal to hi-freq PWM for 12V or 24V LED lights.

Product Code	BWL-6x7-OBD-16
Dimensions	1.29" x 4.21" x 4.8" 33 mm x 107 mm x 122 mm
Channels	6
Input Voltage	12-24 Volts DC
Max. Input Current	25 Amps
PWM Frequency	5/10/20/30 KHz
DMX Ports	2x RJ45 and 2x XLR
Max. Current Load	7 amps per channel (25 amps total)
Max. Output Power	300W/600W (12V/24V)
Weight	300 grams



BETTER WAY
LIGHTING

6 CHANNEL X 7 AMP ON BOARD DISPLAY

Product number: *BWL-6x7-OBD-16*

Component Diagrams

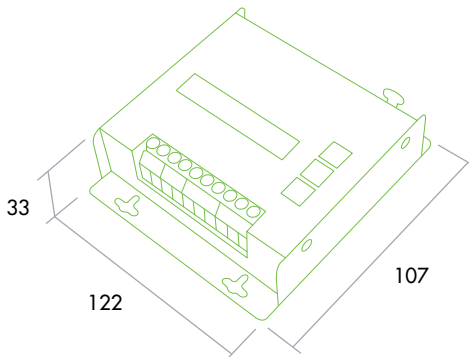
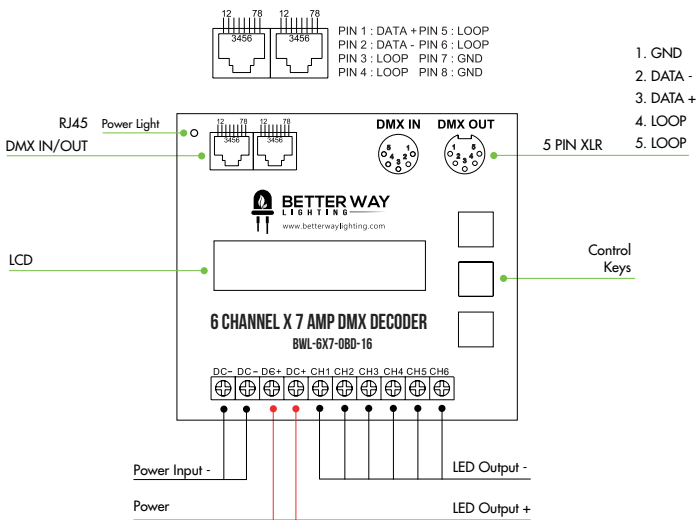

betterwaylighting.com • 778.772.3295

Copyright Better Way Lighting - All Rights Reserved 2018



6 CHANNEL X 7 AMP ON BOARD DISPLAY

Product number: BWL-6x7-OBD-16

Product Operation

MODE Press Mode to switch entries. Long press to go back to main page



Press "Up" or "Down" key to adjust parameters

- Press the MODE button to cycle through DMX channel, 8/16-bit precision, PWM frequency, and set manual brightness levels of each channel.
- DMX control is only active when the DMX channel is displayed.
- Settings are saved between power cycles.

Self Test Program

Set DMX address to 000



BETTER WAY
LIGHTING

6 CHANNEL X 7 AMP ON BOARD DISPLAY

Product number: *BWL-6x7-OBD-16*

Wiring Diagram

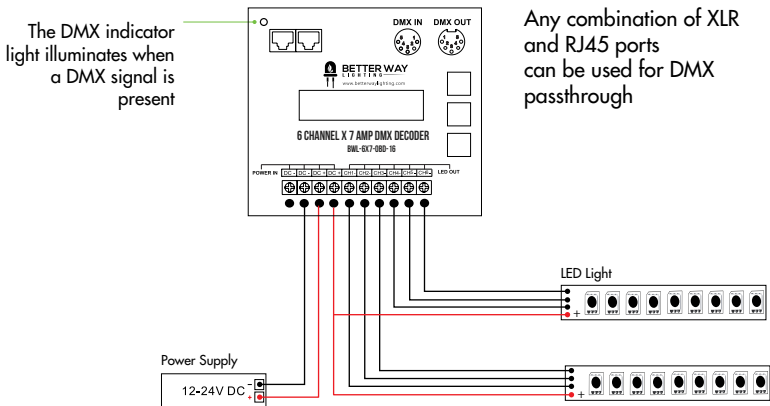

There are two pairs of power input screw terminals for connecting a 12/24V power supply. For high-current applications, make sure to use both pairs of screw terminals so that no single terminal is responsible for >20A of current

A recommended 10 decoders maximum can be chained together on one DMX512 network. To add more unit loads, and for networks longer than 300 meters, a DMX repeater, amplifier, or opto-isolator is needed.

If the dimming console stops transmitting DMX data, the decoder will retain the last values it received until the device is powered off.

betterwaylighting.com • 778.772.3295

Copyright Better Way Lighting - All Rights Reserved 2018



Safety Instructions

- Install in accordance with national and local electrical code regulations.
- This product is intended to be installed and serviced by a qualified, licensed electrician.
- DO NOT connect to high voltage power. Install with a compatible constant voltage power supply or battery with appropriate voltage.
- Only install compatible 12VDC or 24VDC constant voltage luminaires. Make sure to match power supply voltage to the requirements of the LED light. Ignoring this could lead to a potential fire hazard.
- This product is rated for indoor use only and is not protected against moisture.
- The device contains no user-serviceable parts. Attempts to modify the product beyond what is instructed will void the warranty.
- Follow polarity markers as shown on the device.
- Choose an appropriate wire gauge for the maximum potential current load, given your choice of power supply and lights. Keep in mind that the sum total current for all channels is carried over the shared LED+ terminal, so the total current over the LED+ conductor is typically the determining factor in cable choice. You may refer to an AWG table like this one.
- Ensure that power is disconnected whenever inserting or removing wires in screw terminals, or connectors in sockets.
- Ensure that all screw terminals are tightened and all connectors are fully inserted while in operation.



6 CHANNEL X 7 AMP ON BOARD DISPLAY

Product number: BWL-6x7-OBD-16

- There is risk of injury, damage to the components involved, or poor dimming performance, if a lighting configuration is arranged to:
 - i. Power one dimmer using two or more power supplies,
 - ii. Power multiple dimmers from a single power supply, OR
 - iii. Power the same circuit with multiple dimmers, or with multiple channels on one dimmer.
- Only a trained technician with sufficient knowledge of all components involved should ever attempt this.

Installation Procedure

- In the same way that long cable runs cause voltage drop, you may notice some voltage drop over a long enough strip of LED tape. This may manifest itself as progressively dimmer LEDs, or gradual colour shifts down the length of the tape. Options to mitigate the effects of voltage drop:
 - Break long runs into multiple shorter runs, powered by multiple decoders.
 - Power a long strip from the middle, so that the distance to each end is halved.
 - Ensure the length and gauge of head cables are consistent for all lights.
 - Situate the power supply and decoder closer to the light, reducing cable length.
 - Try a larger, higher current power supply.



BETTER WAY
LIGHTING

6 CHANNEL X 7 AMP ON BOARD DISPLAY

Product number: BWL-6x7-OBD-16

- Take the time to test each device ahead of time, especially if they must be installed in a location that is difficult to access.
- For rolls of LED tape, while still on the reel, you can power it on at a low level and view through the open side to check for any dead spots.
- When installing LED tape, if you have any concern that there might be a short circuit between the positive pad and any colour, check for this using a voltmeter before connecting a decoder. A short circuit between LED+ and any output terminal, even if on for only an instant, is likely to permanently damage the decoder.
- A maximum of 10 DMX Decoders may be connected together via the RJ45 or XLR DMX Connection Ports. DMX signal may be extended further by installing a DMX repeater or splitter after the 10th DMX Decoder.